

Deep Freezers

GFL[®]

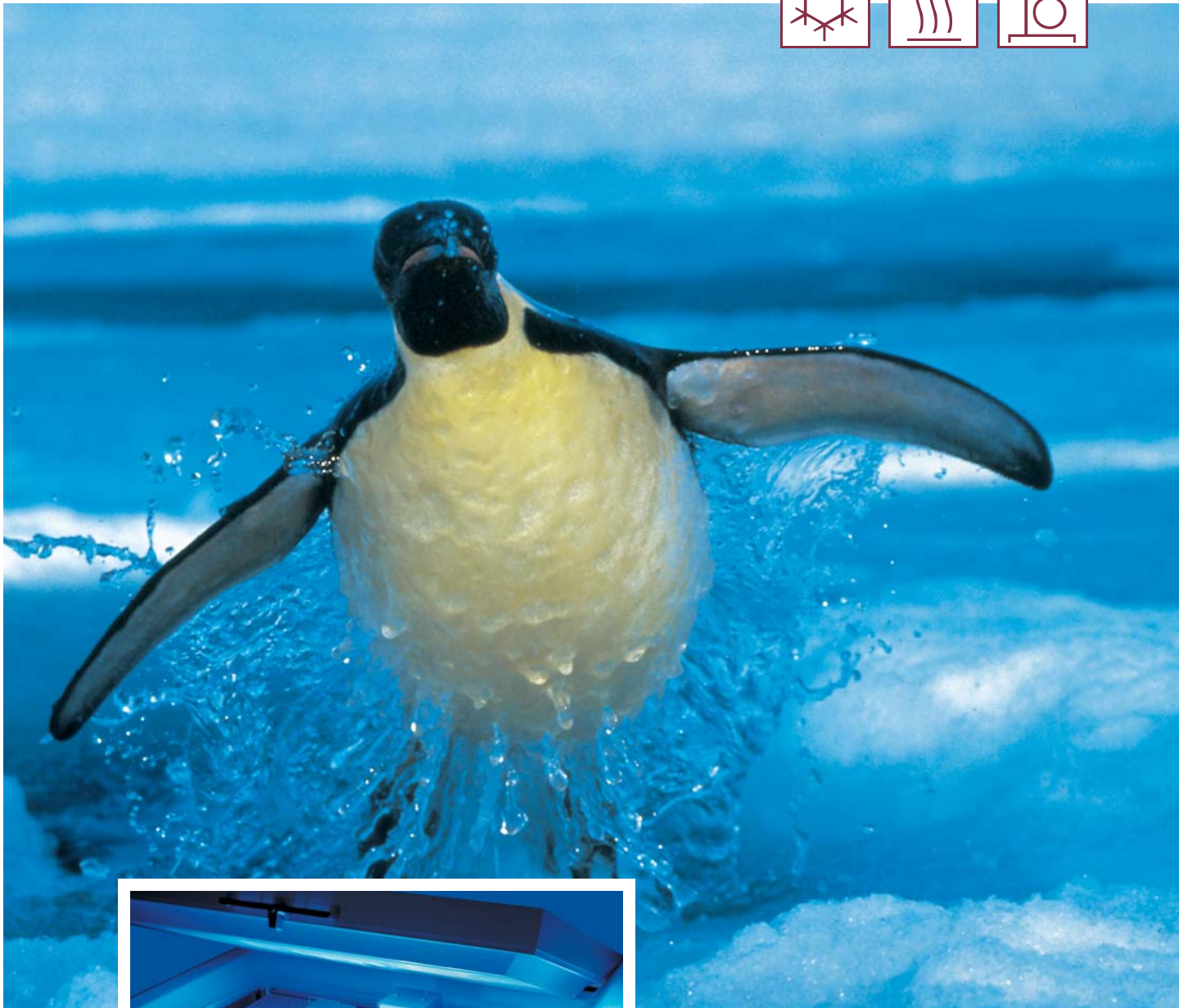

■ Chest and Upright Freezers up to -85°C for long-term storage and quality assurance



Quality built on Tradition

Users in research labs, standard and special labs for medicine, science and industry throughout the world have been profiting from the precision and dependability of our products for almost 40 years, all of which comply with valid European standards and bear the CE mark.

In the future, the success of a product spectrum of laboratory devices that meet the toughest demands on material, functioning and design will continue to be ensured by experience of every-day use in detail, ongoing technical advances and an excellent quality approach.

The phrase „Quality built on Tradition“ encompasses more than just the sum of impressive product innovations. It is also an expression of our corporate policy, which includes a high degree of ready-and-waiting service as our primary customer-friendly service goal.

This applies to all of the GFL laboratory products that are produced exclusively at our plant in Germany - Shakers, Shaking Water Baths, Water Baths, Incubators or Water Stills, Deep Freezers alike.



Secure future

A vested quality demand in accordance with international standards is documented for all GFL laboratory products with the certification to DIN EN ISO 9001:2000, promoting more trust in the permanent high quality level of our products.

In addition to the continuous optimisation of ongoing production processes, the ISO obligation also calls for the commitment to quality awareness of our employees and the continuous development and rapid implementation of preventive measures to ensure quality assurance at a high level.

GFL Unit Control by PC



GFL Deep Freezers are equipped with both microprocessor technique and an interface module for convenient remote control, monitoring and temperature recording via PC.

Trouble-free data transfer is realised via the built-in serial **RS 232 port**. Also available are two further data transfer formats, RS 422 and RS 485, making all of the units compatible,

for example, to the PC software **labworldsoft®**.

This software enables the user, among other things, to control via PC up to 64 lab devices independently from one another and to evaluate all data. Output signals of specified and actual values are available.

Data acquisition is effected online and can be presented either graphically or numerically. Complete measuring

configurations can be stored with all of their current parameters for optimum reproducibility.

System requirements:

Hardware

- Pentium 90 with at least 16 MB RAM, 8 MB free HDD space, mouse
- VGA display; monochrome display with at least 16 grey levels, or colour

Software

- Windows 95/98/2000/NT/ME/XP...

Contents

Page

GFL Deep Freezers

4-5

Upright and Chest Freezers

6-7

Special makes

8-9

Accessories

10-11

Storage system

12-13

Technical data

14-15



Deep Freezers from GFL - enjoying success



6485 Upright Freezer,
500 litres, with storage system
and three additional shelves

The GFL Deep Freezer programme includes Chest and Upright Freezers with capacities ranging from 30 to 500 litres volume. There are 12 Chest Freezers with six different volumes, respectively, five Upright Freezers having three different storage volumes. Both of these product groups are designed for temperatures of 0 °C to -40 °C, or -50 °C to -85 °C in an ambient temperature of up to +28 °C.

- Organic substances which must be stored for extended periods normally represent invaluable assets. Preservation of these substances therefore requires an appropriate storage temperature. Only tested Deep Freezers that operate without any faults or disturbances can guarantee that material such as cell lines or tissue from humans, animals or plants, blood and /or blood fractions, vaccines or reference strains from micro-organisms such as bacteria, yeasts, viruses and fungi will be protected and stored safely and reliably.

The extensive reference list of more than 1400 addresses of well-known users of GFL Deep Freezers in Germany alone attests to this customer requirements for quality and reliability, dependability, long service life and functionality as needed for the application at hand. These are the characteristics that research institutes, universities, hospitals, blood banks and pharmaceutical and chemical companies have come to trust in GFL Freezers. And of course there are a number of companies that use more than just one GFL Deep Freezer.

Our Deep Freezers are also frequently used for various material tests, such as for quality assurance testing of plastics and adhesives, paints and varnishes, ball bearings or road paving materials.

GFL Chest and Upright Freezers are in service in more than 60 countries throughout the world.

in more than 60 countries



GFL Deep Freezers are manufactured using only high-quality, stringently tested materials that are particularly suitable for ultra-low temperatures. The units are extremely quiet, have been approved with the CE mark, are maintenance-free and have the German TÜV seal for „certified safety“ (GS) based on the Federal German Equipment Safety Code. All designs are subject to change. Special makes available on request.

Certified measuring data according to FDA

For customers whose freezer applications call for particularly stringent observance of quality standards, we supply on request detailed records on spatial and temporal temperature constancy basing on the approval guidelines of the US American Health Authority FDA. The instrument test runs are conducted using a calibrated test section in test bays at the factory. Certified test data are archived for a period of ten years at GFL (Order No. 6965, page 13).

User-friendly microprocessor technique

The keypad for the control panel is only the visible tip of the iceberg of the high-performance microprocessor technique which all GFL units are equipped with. All values and data relevant for safe and reliable storage can be entered or retrieved using the clearly laid out and defined symbols. The actual and set temperatures, or the limits for over and under temperatures, for example, can be checked using the LED display. The same applies to the battery capacity and battery loading level. Active operation of an additionally installed safety cooling system is indicated by two extra LED's.

Any faults that may occur are indicated immediately by optical and acoustic alarms. Possible causes for the fault are signalled by code numbers in the display. The user can also set further alarm options as required. Data settings can be protected against unauthorised access by a key-operated security switch.

6380 Chest Freezer, 70 litres, with storage system consisting of racks and boxes



Upright Freezers / Deep Freezers



6483

Upright Freezer,
300 litres



■ Microprocessor-controlled temperature regulation

The microprocessor-controlled temperature regulator, with digital display of actual and set temperature values and digital setting for specified values, operates maintenance-free and is shock resistant.

The regulator is battery-buffered by a constantly charged NC battery that maintains the display of the actual temperature and the alarm functions for 60 hours in case of a power failure. During operation on the line the battery level and the set temperature can be checked by touch control.

■ Energy-saving Deep Freezers

The maintenance-free cooling unit, equipped with fully hermetically sealed high-performance compressors and an air-cooled condenser, ensures short cooling times. The non-flammable refrigerant is free of chlorofluorocarbons (CFC's), as is the insulation installed all around the unit, comprising a 150 mm thick, seamless and diffusion-protected foamed-in polyurethane layer. This insulation is an essential precondition for energy saving operation. The quietly running compressors only give off around 400 W of heat to the environment at maximum cooling temperature.



6481 Deep Freezer, 96 litres, sub-counter installation possible

■ **Ex-proof inside cabinets**

The inside cabinets are manufactured completely of stainless steel (material No. 1.4301), are corrosion resistant and easy to clean.

They are free from ignition sources - an extremely important aspect when storing media with low flash points - and are ex-proof in accordance with BGR 120 10/93, currently 10/1999.

The cooling air outlet is located at the front of the unit, meaning that explosive gases cannot be drawn in when the lid or door is opened.

The magnetic sealing system reliably prevents freezing of the lid or door seals.

All chest lids are balanced and easy to operate. Chest Freezers having a volume of 220 to 500 litres are also equipped with additional insulating cover plates on the cabinet.

Upright Freezers with storage volumes of 300 and 500 litres are equipped with three inside compartments (H 353 mm), each provided with an insulating door to prevent any loss of cold air. Optional shelves can also be installed in the compartments (see page 13).

On request, the cabinet can also be equipped with a set of drawers instead of the inside compartments (see page 13).

■ **Alternative solution: Sub-counter installation**

In daily laboratory practice, especially those Deep Freezers convince that guarantee more than just high-quality protection and reliable longevity of the stored material samples.

Alternative solutions are required that meet customers' demands of practical functionality and flexibility in their range of applications.

The sub-counter Deep Freezer 6481 is an attractive example for this philosophy. After removing the cover

plate, the unit can easily be integrated into a laboratory bench, thus enabling the storage of frozen materials ready at hand at the work station.

Deep Freezer 6481 offers a large storage volume while at the same time requiring little space (96 l cabinet volume / 3 drawers) and operates in a temperature range between -50 °C and -85 °C.

Further details: Accessories / external temperature recorder (page 13) and technical data (pages 16 and 18).



6481 Deep Freezer, 96 litres, with cover plate, as stand-alone unit

Upright Freezers / Deep Freezers



6345
Chest Freezer,
500 litres

■ Powder-coated housing

The housings are made of powder-coated, electrolytically galvanised sheet steel.

As standard, all Deep Freezers come with double wheel swivel castors, two of which can be locked, for transport to the place of use and for mobile applications. (castors for model 6481)

■ Controlled access

The lids and doors of the freezer units can be locked, making unauthorised removal of material impossible. The easy-to-use control panel provides controlled access through the use of a key-operated security switch, ruling out any inadvertent temperature maladjustment.



■ Multiple alarm messages

As standard, the Deep Freezers come with a potential-free changeover contact for connection to an internal alarm system, or to the central I&C system. They are also provided with a connection for a piezoelectric buzzer for simple remote notification of alarms (max. cable length: 100 m with a cable diameter of 0.14 mm²).

In the event of a fault (e.g. excess temperature, under temperature, loss of power, sensor break/short-circuit, etc.), an optical and acoustic alarm is issued. The cause for the fault is shown in the display as a defined code number.

The limit values for alarms (0 - 20 K) for excess and under temperatures can be set individually by the user. Other optional alarm messages can also be set by the user:

- ▶ Suppression of alarm message after a power failure (0 to 999 minutes); this feature is useful, for example, if emergency backup power systems are tested regularly.
- ▶ Suppression of alarm message on violation of a temperature limit (0 to 999 minutes). The set value remains stored until the next change is made. This can be useful, for example, when large quantities of refrigerated goods are removed/put into storage frequently.
- ▶ Suppression of alarm message on violation of temperature limits (0 to 999 minutes). The set value is cancelled when the set time expires. This can be useful, for example, when refrigerated goods are removed/put into storage only occasionally.

■ Guaranteed supply of spare parts

Spare parts can be delivered from stock for all Deep Freezer models. GFL guarantees their availability for ten years.

■ Intensive quality control

Customers' trust in our products is ensured by our intense quality assurance procedure. This is why GFL Deep Freezers are tested with state-of-the-art testing devices before they leave our factory.



6382 Chest Freezer, 100 litres



6384 Chest Freezer, 300 litres

Special makes

- The service supplied to our customers does not end at the convincing high quality standard of our Deep Freezers. In order to enhance their variability and, thus, the benefits for the user, we also supply customised equipment on request, tailored to the individual requirements of tasks that demand special solutions for storage.



6485 Upright Freezer, 500 litres, custom design with two standard compartments and a large drawer unit made of stainless steel with perforated raised side elements and a 10 mm thick insulating plastic cover with a grip hole. Storage system for test plates and boxes.

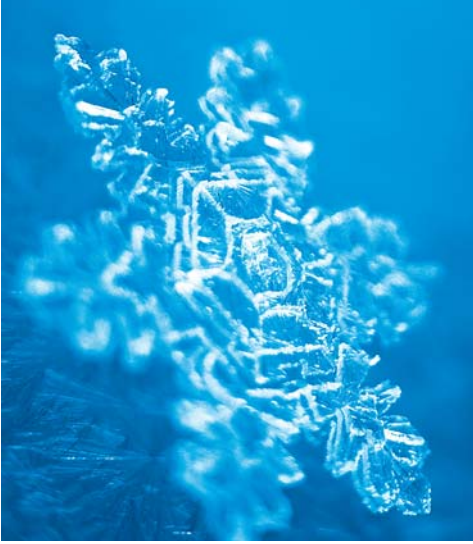

Whether it be a microtiter plate, a cryo box or dinosaur bones - handling of particularly small or very large bulky storage goods is facilitated for the individual case at hand by the appropriate drawer, divider or compartment solution.

Sample solutions for storage task:

- ▶ Drawers with modified heights for Upright Freezers
- ▶ Combination of inside compartments/ drawers for Upright Freezers
- ▶ Locking systems for inside compartments of Upright Freezers
- ▶ Inside compartment covers made of acrylic glass for Upright Freezers
- ▶ Drawer dividers for Upright Freezers
- ▶ Reinforced shelves for Upright Freezers
- ▶ Cabinet dividers for Chest Freezers
- ▶ Storing tubs in three different sizes
- ▶ Specially dimensioned storage systems
- ▶ Installation of additional leadthroughs
- ▶ Installation of additional temperature sensors
- ▶ Separated storage and motor units to allow deep freeze storage in a sensitive working area
- ▶ Equipping of our Deep Freezers with a self-dialling alarm phone system enhances storage safety



6485 Upright Freezers, 500 litres, custom design with five inside compartments and inside doors made of 10 mm thick acrylic glass, with grip hole. Storage system for test plates and boxes.



Accessories

- The range of application for our Deep Freezers is expanded using accessories appropriate for the task at hand. GFL accessories for Chest and Upright Freezers therefore not only enhance the reliability and performance of our range of products, but also improve their economic efficiency.

Safety cooling system

(Refrigerant vessel not included in scope of supply)

A power outage or a fault with the unit can often result in thawing of valuable material samples, usually with the associated financial losses and lost work time.

Safety cooling systems protect against non-regulated rises in temperature by keeping the temperature in the cabinet constant at a freely selectable value (0 to -70°C) by controlled injection of LN_2 or CO_2 when the main cooling system fails.

There are four different cooling systems for two different refrigerants available for protecting highly sensitive materials against uncontrolled warming or thawing. These systems can be installed in Chest Freezers with a volume of at least 70 l and in Upright Freezers starting at a volume of 300 l storage space.

The most commonly used refrigerant for safety cooling systems, and the one which is available nearly everywhere throughout the world, is CO_2 .

LN_2 is used in cases the stored material must not come into contact with CO_2 . The use of LN_2 refrigerant vessels requires an insulated supply line that is available with the vessel supplier.

The four types of cooling systems differ in the power supply used for each system:

- ▶ Version 6946a and 6947a are designed for connection to a 230 Volt emergency power system (a.c.),



- **Order No. 6946a**
 LN_2 safety cooling system for 230 V a.c. (emergency power)
- **Order No. 6946b**
 LN_2 safety cooling system for battery-powered operation
- **Order No. 6947a**
 CO_2 safety cooling system for 230 V a.c. (emergency power)
- **Order No. 6947b**
 CO_2 safety cooling system for battery-powered operation

- ▶ Version 6946b and 6947b are, in case of a power failure, supplied with power by a battery provided with the system for around 60 hours. The battery is recharged automatically when normal power supply is restored.

Distribution lines are required if two or three CO_2 bottles are connected simultaneously to the freezer unit (see Order No. 6948 and 6949). The CO_2 bottles must be provided with a rising pipe and must not be connected to a pressure limiter.

At a setting of -60°C for the safety cooling, consumption of CO_2 or LN_2 is about 1.2 kg per hour.



- **Order No. 6948**
Distribution line for two CO_2 bottles
- **Order No. 6949**
Distribution line for three CO_2 bottles

Distribution line

(CO_2 bottles not included in scope of supply)

The distribution line for safety cooling system 6947 can be ordered complete with all requisite connectors, tubes and materials for wall mounting.

■ Order No. 6960

Water cooling

A heat exchanger is installed in place of the air-cooled liquefier. The advantage here is that the heat exchanger considerably reduces the heat given off by the unit to the environment, at the same time, expanding the permissible ambient temperature range in which the unit can be operated.

Water supply is regulated by the Freezer. The heat exchanger can be connected to a recirculation system or to the internal water supply system. (Connecting points on unit: outside thread connector for pressure hose 1/2 " with lock nut.) A water cooling system can be installed in GFL Deep Freezers with a volume of at least 220 litres.

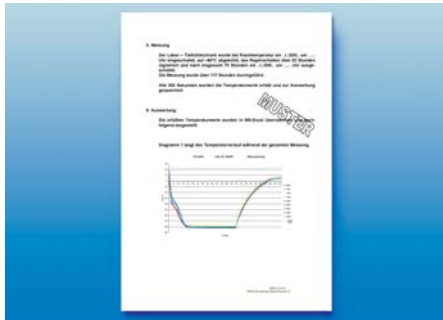

■ Order No. 6965

Qualification data record

The GFL qualification data record provides detailed documentation of the spatial and temporal temperature constancy in our Deep Freezers. All requested test and measurement data are established at our factory using a calibrated test section and archived at GFL for one decade.

GFL customers can use this device-specific qualification data record to demonstrate the quality of their products when they must, for example, comply with the special approval guidelines defined by the US American Health Authority FDA.



■ Order No. 6950

Chart recorder

The chart recorder ensures continuous recording of the inside cabinet temperature on pressure sensitive paper. The current measured value is recorded with constant, clear legibility without the use of expensive ribbons or ink.

The chart recorder is designed for continuous operation and is equipped with three paper feed options:

- 25 mm in 24 hours
- 25 mm in 2 hours
- 25 mm in 1 hour

Depending on the set feed rate, a roll of paper for the recorder (9.2 m in total length) will last from 15 to 368 days. Except for easy replacement of the paper rolls, the chart recorder is completely maintenance-free. The recorder can be installed in Chest Freezers with a storage volume of 70 and 100 litres and in Upright Freezers with a storage volume as of 300 litres. In combination with the other GFL Freezers the chart recorder is mounted in a separate housing.



■ Order No. 6952

for Upright Freezers 6443 and 6483 (300 l volume)

■ Order No. 6953

for Upright Freezers 6445 and 6485 (500 l volume)

Drawer sets for Upright Freezers

The cabinet of Upright Freezers can also be equipped with a set of four drawers in place of the three insulated compartments. These drawers are made of stainless steel with front panels made of 10 mm thick polystyrene insulating plates. Ball bearings and slide rails ensure easy and level motion.

Storage system

■ The GFL storage system is flexibly structured. Optimised utilization of the storage space is achieved using racks for boxes, microtiter and DeepWell plates, thus reducing the costs per samples that are stored.

The stainless steel racks reduce overall weight and are easy to handle. Use of these drawers guarantees well-arranged and safe storage of the entire sample material.

The box capacity for storing samples can be varied, permitting the system to be adapted to a variety of applications. The boxes are made of water-resistant coated cardboard. There are three different dividers available for the boxes. ►

Boxes included in the GFL storage system programme:
6970 (H 50 mm) and
6980 (H 75 mm)



Racks included in the GFL storage system programme for boxes, microtiter and DeepWell plates

Inner dividers for boxes 6970 and 6980

- **Order No. 6971**
for 100 (Division 10 x 10) test tubes with a diameter of 11 mm / section dimensions 12x12 mm
- **Order No. 6972**
for 64 (Division 8 x 8) test tubes with a diameter of 14 mm / section dimensions 15x15 mm
- **Order No. 6973**
for 49 (Division 7 x 7) test tubes with a diameter of 16 mm / section dimensions 17x17 mm



Chest Freezers

Model	Volume	Contents	Order No. for 1 box	Number of racks per unit	Order No. for 1 rack	Number of boxes/plates per rack	Number of boxes/plates per unit
6340/6380	70 l	50 mm box height	6970	8	6901	6	48
		75 mm box height	6980	8	6902	4	32
		Microtiter plates	–	6	6905	36	216
		DeepWell plates	–	6	6905	12	72
6342/6382	100 l	50 mm box height	6970	15	6901	6	90
		75 mm box height	6980	15	6902	4	60
		Microtiter plates	–	10	6905	36	360
		DeepWell plates	–	10	6905	12	120
6343/6383	220 l	50 mm box height	6970	18	6903	10	180
		75 mm box height	6980	18	6904	7	126
		Microtiter plates	–	12	6906	60	720
		DeepWell plates	–	12	6906	20	240
6344/6384	300 l	50 mm box height	6970	21	6903	10	210
		75 mm box height	6980	21	6904	7	147
		Microtiter plates	–	15	6906	60	900
		DeepWell plates	–	15	6906	20	300
6345/6385	500 l	50 mm box height	6970	40	6903	10	400
		75 mm box height	6980	40	6904	7	280
		Microtiter plates	–	28	6906	60	1680
		DeepWell plates	–	28	6906	20	560

Upright Freezers

6443/6483	300 l	50 mm box height	6970	24	6907	9	216
		75 mm box height	6980	24	6908	6	144
		Microtiter plates	–	24	6911	36	864
		DeepWell plates	–	24	6911	12	288
6445/6485	500 l	50 mm box height	6970	24	6909	15	360
		75 mm box height	6980	24	6910	10	240
		Microtiter plates	–	24	6912	72	1728
		DeepWell plates	–	24	6912	24	576

Additional shelves for Upright Freezers

Models	Volume	Order No. for one shelf
6443/6483	300 l	6954
6445/6485	500 l	6955

- ▶ Upright Freezers having a storage volume of 300 and 500 litres come with three compartments as standard equipment. As an option, each compartment can be sectioned with one additional shelf for optimal utilisation of the internal volume of the unit.

Technical data

■ The GFL programme for Chest and Upright Freezers, with 17 model options and seven different storage volumes, is the result of almost 40 years of production experience and focuses on uncompromising and perfect safety and reliability.

The following table lists the performance features oriented to the specific requirements for actual every-day use for each of the individual products.

Chest Freezers								
Order No.	Volume	Temperature range °C	Inner dimensions W x D x H mm	Outside dimensions (A) W x D x H mm	Outside dimensions (B) W x D x H mm	Power kW	Net weight approx. kg	Packing volume approx. m ³
6340	70	± 0 bis – 40	600x 350x 340	836x 685x 1055	836x 585x 1055	0.6	100	1.1 ●
6341	30	± 0 bis – 40	500x 305x 200	700x 600x 905	700x 500x 905	0.6	70	0.6 ■
6342	100	± 0 bis – 40	710x 440x 340	960x 790x 1080	960x 690x 1080	0.6	180	1.9 ●
6343	220	± 0 bis – 40	840x 460x 580	1450x 870x 1040	1450x 770x 1040	0.6	210	3.0 ●
6344	300	± 0 bis – 40	1000x 500x 600	1610x 910x 1060	1610x 810x 1060	0.6	240	3.0 ●
6345	500	± 0 bis – 40	1440x 580x 600	2060x 1000x 1060	2060x 900x 1060	0.6	310	3.4 ●
6380	70	– 50 bis – 85	600x 350x 340	836x 685x 1055	836x 585x 1055	1.2	120	1.1 ●
6381	30	– 50 bis – 85	500x 305x 200	700x 600x 905	700x 500x 905	1.2	90	0.6 ■
6382	100	– 50 bis – 85	710x 440x 340	960x 790x 1080	960x 690x 1080	1.2	200	1.9 ●
6383	220	– 50 bis – 85	840x 460x 580	1450x 870x 1040	1450x 770x 1040	1.2	230	3.0 ●
6384	300	– 50 bis – 85	1000x 500x 600	1610x 910x 1060	1610x 810x 1060	1.2	260	3.0 ●
6385	500	– 50 bis – 85	1440x 580x 600	2060x 1000x 1060	2060x 900x 1060	1.2	330	3.4 ●
Upright Freezers								
6443	300	± 0 bis – 40	600x 450x 1100	990x 865x 1940	916x 785x 1940	0.6	240	2.8 ●
6445	500	± 0 bis – 40	600x 760x 1100	990x 1175x 1940	916x 1095x 1940	0.6	310	3.5 ●
6481	96	– 50 bis – 85	430x 430x 510	900x 770x 890	900x 750x 865	1.2	150	1.1 ●
6483	300	– 50 bis – 85	600x 450x 1100	990x 865x 1940	916x 785x 1940	1.2	270	2.8 ●
6485	500	– 50 bis – 85	600x 760x 1100	990x 1175x 1940	916x 1095x 1940	1.2	340	3.5 ●
230 V one-phase voltage a.c. / 50 Hz (other voltages and frequencies on request)						All designs are subject to change without notice		

Delivered free German border, fas German seaport or fca German airport including packing in:

- = cardboard box
- = wooden crate,

shipment through GFL's forwarders. If other forwarders are to be used, we deliver ex works.

Sometimes, narrow doors demand smaller unit widths and/or depths when the Freezers are transported to the place of use. The product table (P. 14) shows both dimensions (A and B), illustrated on this page.

Chest Freezers / Upright Freezers:

The **outside dimensions (A)** given here are the actual dimensions.

Chest Freezers: The **outside dimensions (B)** given here refer to the depth dimension after removing the lock and the lid hinges, the cable connections and the connector for the safety cooling system, the chart recorder, the power switch and the control panel; with the height dimensions referring to when the lid is opened.

Upright Freezers: The **outside dimensions (B)** given here refer to the width dimensions after removing the lock and to the depth dimensions without the cable connection and the connector for the safety cooling system, the chart recorder, power switch and control panel.

Chest Freezers

Models **6343, 6344, 6345, 6383, 6384, 6385** with 220, 300 and 500 litres storage volume

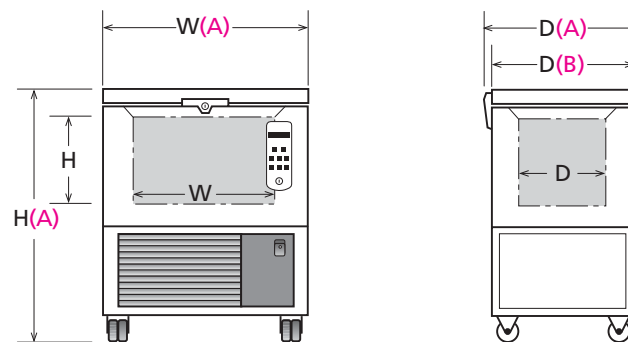
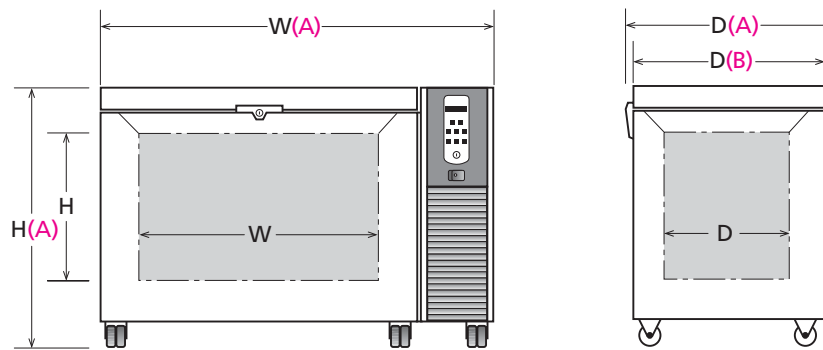

Chest Freezers

Models **6340, 6341, 6342, 6380, 6381, 6382** with 30, 70 and 100 litres storage volume

Upright Freezers

Models **6443, 6445, 6483, 6485** with 300 and 500 litres storage volume

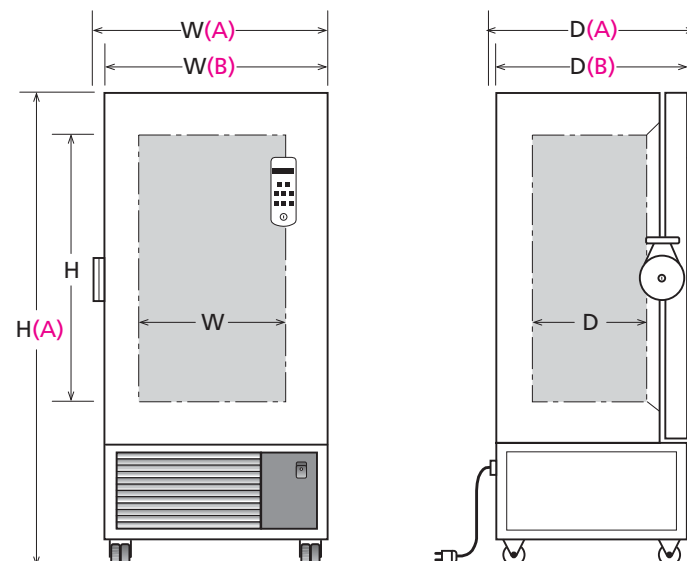

Sometimes, narrow doors demand smaller unit widths and/or depths when the Freezers are transported to the place of use. The product table (page 16) shows both dimensions (A and B), illustrated on this page.

Upright Freezer 6481 (suitable for sub-counter installation):

The **outside dimensions (A)** given here are the actual dimensions.

The **outside dimensions (B)** given here refer to the depth dimension after removing the door, the cable connection and the housing of the control panel and the height with the cover plate removed.

The Upright Freezer requires **a distance of at least 60 mm** from other units or walls, thus providing sufficient cooling air supply.

Upright Freezer

Model **6481**

with 96 l storage volume,
suitable for sub-counter
installation

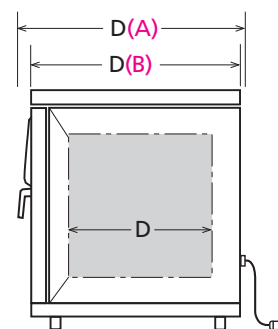
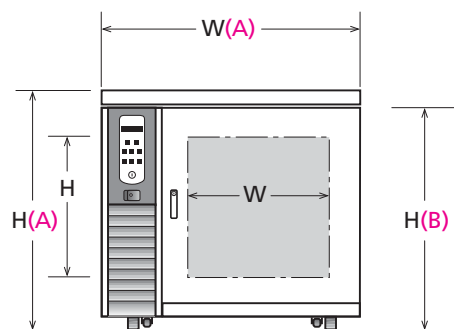
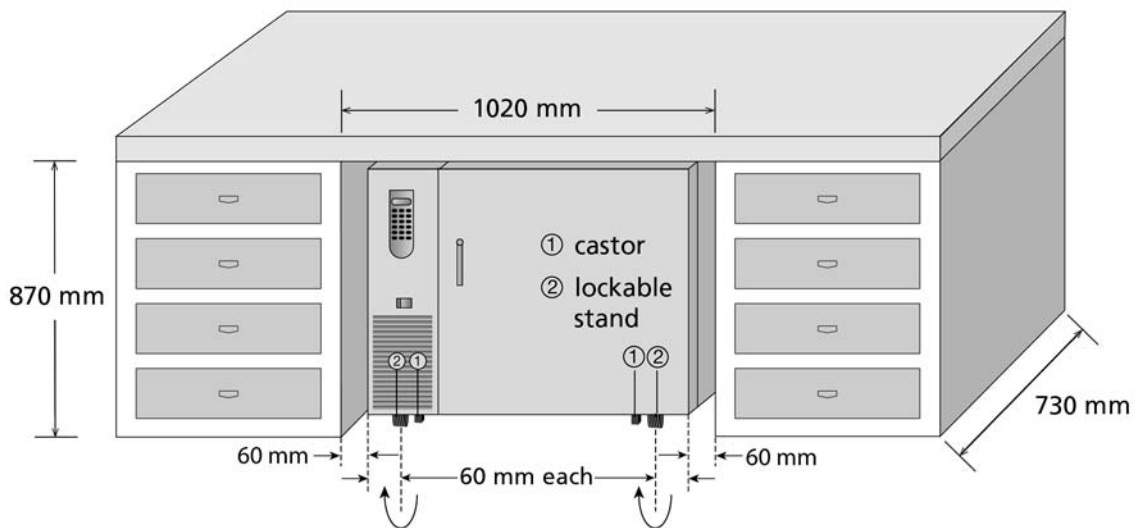



GFL Gesellschaft für Labortechnik mbH

P.O. Box 11 52 · 30927 Burgwedel / Germany
Schulze-Delitzsch-Strasse 4 · 30938 Burgwedel / Germany
Phone ++ 49 (0)5139 99 58 -0 · Fax ++ 49 (0)5139 99 58 21
E-Mail: info@GFL.de · Internet: www.GFL.de