

A measured step forward

EASYDOS Peristaltic V



Operating & Maintenance Instruction

Read these operation & maintenance instructions
before start up!

To be held for future reference.



Table of contents

Warnings used in this Operation & Maintenance Manual	4
Parts designation	5
Peristaltic pump EASYDOS Peristaltic V	6
Basic equipment / properties	6
Technical Data	7
Installation and safety regulations	7
Installing the unit	8
Setting the mode of operation	9
Mode of operation 1 (adjustable rate of delivery)	9
Mode of operation 2 (one or two time relays)	10
Mode of operation 3: 1 time relay with adjustable rate of delivery on channel 1	12
Mode of operation 4: Time relay on channel 1 and adjustable rate of delivery on channel 2	13
Electrical connection	13
Putting into service Start-up	13
Safety in case of a ruptured pump tube	14
Maintenance / Wearing parts / Spare parts	14
Changing of the tube without disassembly of rotor	15
Declaration of conformity	16
Declaration of harmlessness	17
Warranty	18

Warnings used in this Operation & Maintenance Manual

This Operation & Maintenance Manual contains vital information, which may endanger people, the environment and the dosing pump/system if disregarded. These statements are identified by the following symbols:



DANGER!

Refers to an imminent danger.

Non-compliance can lead to death or extremely serious injury.



WARNING!

Refers to a potentially hazardous situation. Non-compliance can lead to death or serious injury.



CAUTION!

Refers to a potentially hazardous situation. Non-compliance can lead to minor injury or property damage.



NOTICE!

Appears in conjunction with safety instructions, which may endanger the pump/system and its operation if disregarded.



IMPORTANT!

Draws attention to supplementary information to make the work easier and ensure trouble free operation.

Markings which are affixed directly to the pump, such as

- Cable markings
- Markings for process fluid connections

must be observed without fail and must remain fully legible at all times.

Parts designation

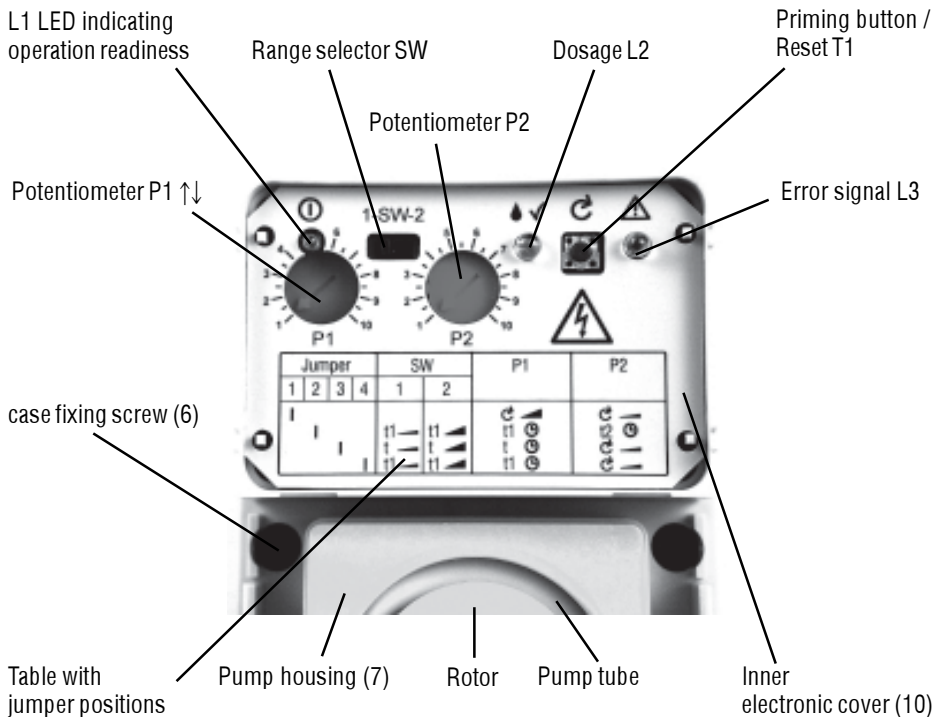

Cover of electronic removed

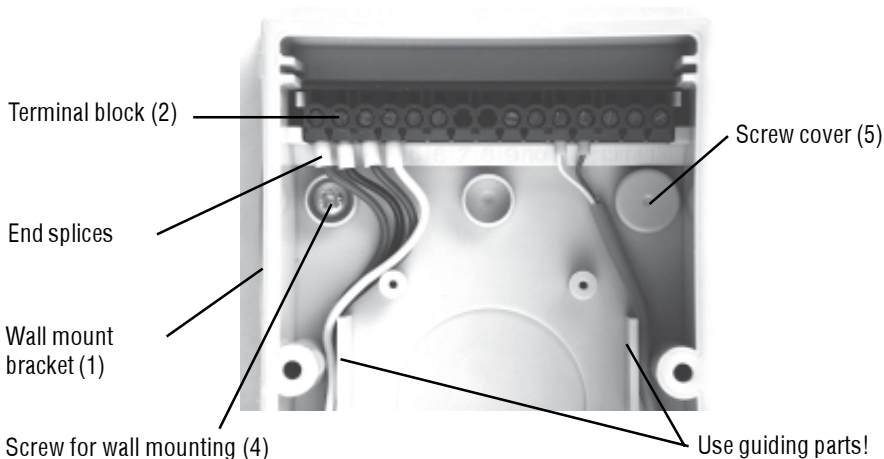

Wired installation housing

Peristaltic pump EASYDOS Peristaltic V

Universal peristaltic pump with closed-loop revolution controlled drive for continuous and time relay controlled dosage of process fluids (4 modes of operation).

Basic equipment / properties

- self-priming peristaltic pump with genuine closed-loop speed control (GCL-technology)
- **genuine closed-loop** speed control: rotor speed remains exactly at the adjusted value independent from material and state of the pump tube, viscosity, suction height and independent from fluctuations of ambient temperature and operating voltage within the specified ranges
- rate of delivery adjustable between **7 ml/h** and **400 ml/h**
- due to the high torque capabilities of the DC motor, applicable even for smallest capacities against pressure of up to 2 bar (29 psig) or 10 m (32.8 ft.) water column or viscose media. If required, different tube materials may be applied
- **double ball bearing** ensures high lifetime of the device
- specially designed pump housing cover for easy and fast changing of the pump tube
- compact housing, **easy to install**
- mode of operation 1: adjustable rate of delivery with two potentiometers (P1 gross and P2 fine adjustment)
- mode of operation 2: adjustable time intervals (two time relays) corresponding to P1 and P2
- mode of operation 3: adjustable time interval (one time relay) with adjustable rate of delivery
- mode of operation 4: adjustable time interval (channel 1) and adjustable rate of delivery (channel 2)

Technical Data

Capacity:	7 – 400 ml/h (water at 20° C (68° F), suction height 1.7 m)
Pump tube:	0.8 x 1.6 mm
Recommended operation time:	up to 8 h/d
Duty cycle:	100 %/h, if adjusted to <1/3 of max speed 50 %/h, if adjusted to >1/3 of max speed of the recommended operation time
System back pressure:	2 bar (29 psig) max.
Ambient temperature:	10 - 50° C (50 - 122° F)
Operating voltage:	180-264 VAC, 50-60 Hz (200-240 VAC +/-10%)
Fuse:	200 mA, semi-delay, 5 x 20 mm
Power consumption:	16 VA max.
Tube connections:	Clamping connection for hoses 4/6 mm
Dimensions:	92 x 170 x 130 mm (W x H x D)
Weight:	1.2 kg (2.65 lbs.)

Installation and safety regulations

- Pump must be installed in a place protected from mechanical impact, vapours, acids and lyes.
- Pump must be installed above the level of the barrel or supply tank, containing the product.
- Pump must be installed vertically with tube connections facing downward.

CAUTION!

The pump must not be used for inflammable products! When pumping dangerous products such as acids, lyes, chlorous or biotechnological products all regulations concerning the product have to be obeyed and all safety measures have to be carried out. Special safety measures (for example collecting basin) are necessary in case of damage of the pump tube to prevent damages and to inhibit any danger to persons and environment.

Installations having tall delivery heights must be designed with pumps mounted so that suction lift is smaller than pressure head. Peristaltic pumps work better when operating against design system back pressure. **Each meter of height increases the resulting pressure by 0,1 bar (with waterlike fluids).**

- If pump discharges into pressurized system, a check valve has to be installed.



CAUTION!

Installing the unit

- On the inner sides of the big coloured front hood in the area of the tube retainer there are two slots of about 9 mm length. Loosen front hood carefully at these two slots with a screw driver and remove front hood by hand (see last page).
- After removing the front hood four housing screws (recessed head screws) are visible. Loosen those and pull off device from installation housing.
- Mount installation housing with the provided screws and fixings at the wall. Make sure the installation housing is not twisted when fastened with screws on an uneven surface.



IMPORTANT!



CAUTION!

- **IMPORTANT!**
Use the four screw-caps (5) to seal the case from moisture
- Peel off power cable, strip the insulation of the stranded conductors and fix end splices. If thicker cables are used, dismantling should begin at the inner side of the threaded cable gland. Insert the cable into the threaded cable gland. Insert cable or stranded conductors in the sides of the installation housing and lead them using the little guiding parts, so that the cables do not touch the motor.

CAUTION!

Depending on the operation mode the motor may heat up - this is not a malfunction!

- Terminal block arrangement in the upper part of the installation housing.
- Fasten union nut of the threaded cable gland. A high IP-Protection class is only achieved in this way.
- Place device on installation housing and push onto it. When doing this take care that no cables or stranded conductors are squeezed.
- Fasten device with the four housing screws at the installation housing.

IMPORTANT!

Turn screws only until the gasket is pressed. If the screws are turned too far, the plastic thread in the installation casing is twisted off!

- Remove cover of the pump housing by pulling it downward.
- Attach supply tube on the left and discharge tube on the right side of the tube retainer.
- Fasten tubes with tube clips respectively threaded joints.
- If required replace stopper in the middle of the tube retainer with the drain-off-connection piece and attach additional tube, which - in case of a damaged tube - drains the process fluid back to the supply tank.
- Attach cover of the pump housing and press until it stops.
- Remove cover of electronic and make adjustments (see „Setting the mode of operation“). Afterwards, put electronic cover back on.
- Place front hood and press till it stops.
- Examine if there are any measures to be carried out that are described in the safety regulations of the provided product. If so, carry out the necessary measures.



IMPORTANT!

Setting the mode of operation

The desired mode of operation is selected with a jumper (small electrical bridge) on the electronic circuit board by simply putting it on the corresponding pin couple. Default setting of the device is mode of operation 1 (shown in the figure on the right side). If another mode of operation is required, pull jumper upwards with a forceps and put it onto the pin couple that corresponds to the desired mode of operation.

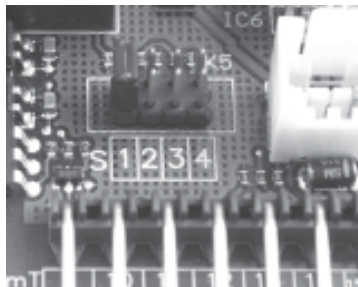

Mode of operation 1 (adjustable rate of delivery)

With mode of operation 1 the revolutions of the rotor of the pump can be adjusted to a fixed value. Potentiometer P1 is used for gross speed adjustment, potentiometer P2 is used for fine speed adjustment. The range selector switch SW is out of function.

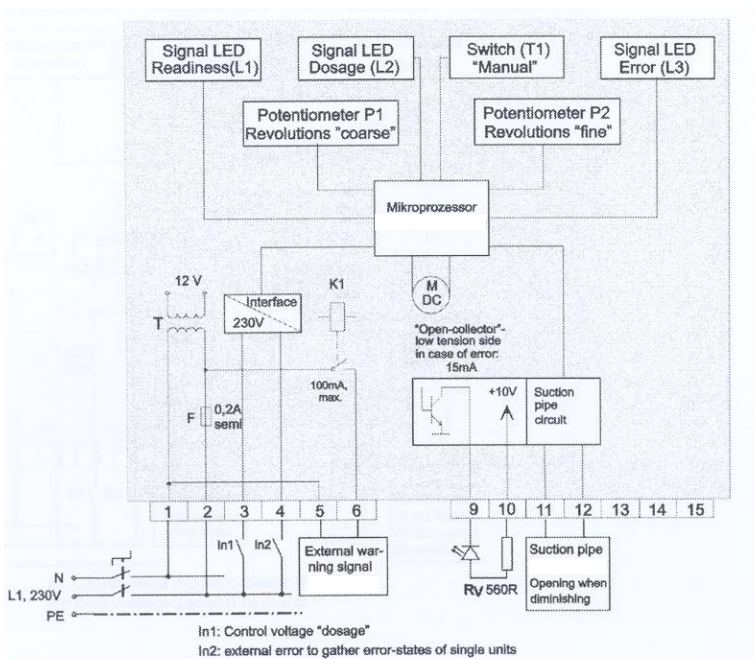



NOTICE!

- Set jumper on printed circuit board to position 1 (if not default).
- Attach neutral conductor to terminal 1, power supply (230 V AC) to terminal 2 and attach control current (230 V AC) to terminal 3.
- If no controlling voltage is available, terminals 2 and 3 must be jumped.

NOTICE!

Power supply on terminal 2 and control current terminal 3 must be in phase!

- Potentiometer P1 is used for gross adjustment of rotor speed (revolutions) and thus the rate of delivery. Potentiometer P2 is used for the fine adjustment of the rotor speed (about 10% of the range of P1). If the control current at terminal 3 („In1“) is active, the pump discharges with the rate of delivery corresponding to the settings of P1 and P2.
- On terminal 11 and 12 a suction line with float switch for supply tank empty detection may be installed. If a supply tank empty is detected, the signal LED L3 blinks. Terminals 5 (neutral conductor) and 6 (phase) lead operation voltage to switch on an external visual or audible warning signal. An optional LED in series with a resistor (560 Ohm) between terminals 9 and 10 may be added.



NOTICE!

NOTICE!

If no suction pipe with float switch is installed, terminals 11 and 12 must be jumped!

- With active control voltage on terminal 4 („In2“) terminals 5 (neutral) and 6 (phase) are active (230V AC) and an optional LED in series with a resistor (560 Ohms) between terminals 9 and 10 is on. This special mode is intended to gather the error-state of any device of a more-device-dosage-station to the last device, which gives the error-state to a computer system or additional external warning signal.

Mode of operation 2 (one or two time relays)

- Set jumper on printed circuit board to position 2 (default is position 1)
- Attach neutral conductor to terminal 1 and power supply (230 V AC) to terminal 2.
- Attach control voltage 1 (230 V AC) to terminal 3 and control voltage 2 (230 V AC) to terminal 4.

NOTICE!

Control voltages (terminals 3 and 4) and operational voltage (terminal 2) must be cophasal!

- With potentiometer P1 a time period between 6 and 60 seconds (selector switch SW in position 1) or between 60 and 600 seconds (selector switch SW in position 2) can be set.
- With a control voltage (230 V AC) at terminal 3 the pump delivers corresponding to the adjusted operation time with constant rotor speed (delivery rate of about 6 ml/min).



NOTICE!

- With potentiometer P2 a time period between 1 and 20 seconds can be set.
- With the control voltage „In2“ (230 V AC) at terminal 4, the peristaltic pump operates for the set time at constant rotor speed (capacity approx. 6 ml/min).
- In case the control voltages "In1" or "In2" get inactive before the adjusted operation time is terminated, the operation is stopped immediately. If this/premature stopping of the operation is not desired, "**operation mode B**" must be selected. For this mode, 3 additional pins on the printed circuit board near the LED for the warning signal are designated. A jumper must be set that the pin marked with "B" and the pin in the middle are connected. In this operation mode the operation time is started with an impulse that last at least 400 ms. A premature termination of operation will not happen.
- On terminals 11 and 12 a suction line with float switch for supply tank empty detection may be installed. If a supply tank empty is detected, the signal LED L3 blinks. Terminals 5 (neutral conductor) and 6 (phase) lead operation voltage to switch on an external visual or audible warning signal. An optional LED in series with a resistor (560 Ohm) between terminals 9 and 10 may be added.
- **NOTICE!**
If no suction line with float switch is installed, terminals 11 and 12 must stay bridged!

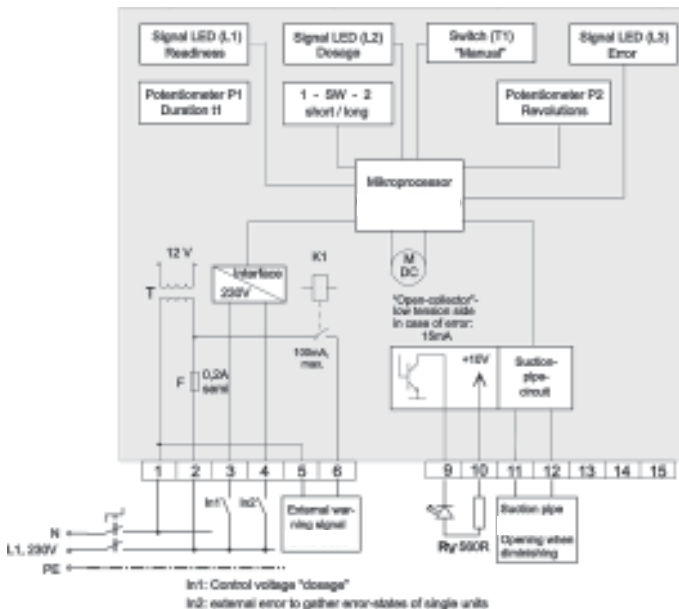

Mode of operation 3: 1 time relay with adjustable rate of delivery on channel 1



NOTICE!

- Set jumper on printed circuit board to position 3 (default is position 1)
- Put neutral conductor to terminal 1 and phase / mains (230 V AC) to terminal 2
- Put controlling voltage (230 V AC) to terminal 3 („In1“).
- **NOTICE!**
Controlling voltage terminal 3 and mains on terminal 2 must be cophasa!
- With potentiometer P1 a time period between 6 and 60 seconds (select/selection/selector switch SW in position 1) or between 60 and 600 seconds (select/selection/selector switch SW in position 2) can be set.
- With potentiometer P2 the rotor speed may be adjusted to a rate of delivery between 0.1 and 2 ml/min.
- With a control voltage (230 V AC) at terminal 3 the pump delivers corresponding to the preset operation time with constant rotor speed that is corresponding to potentiometer P2.

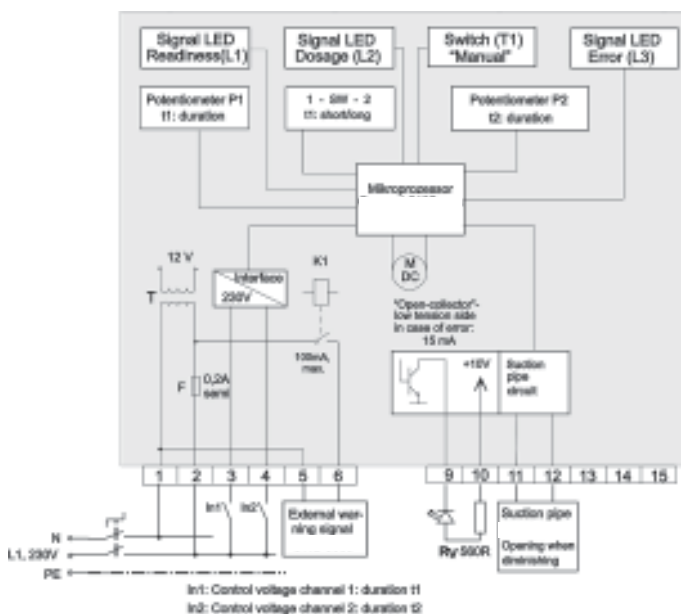

- On terminals 11 and 12 a suction line with float switch for supply tank empty detection may be installed. If a supply tank empty is detected, the signal LED L3 blinks. Terminals 5 (neutral conductor) and 6 (phase) lead operation voltage to switch on an external visual or audible warning signal. An optional LED in series with a resistor (560 Ohm) between terminals 9 and 10 may be added.

- With active control voltage on terminal 4 („In 2“) terminals 5 (neutral) and 6 (phase) are active (230V AC). An optional LED is in series with a resistor (470 Ohms) between terminals 9 and 10. This special mode is intended to gather the error state of any device of a multiple device dosage station to the last device, which forwards the error state to a computer system or an additional external warning signal.

Mode of operation 4: Time relay on channel 1 and adjustable rate of delivery on channel 2

- Set jumper on printed circuit board to position 4 (default is position 1)
- Wiring of the device in accordance to the wiring diagram "Mode of operation 2". Attach neutral conductor to terminal 1 and power supply (230 V AC) to terminal 2. Attach control current 1 (230 V AC) to terminal 3 ("In1") and control current 2 to terminal 4 ("In2").

Caution!

Power supply on terminal 2 and control current at terminal 3 and terminal 4 must be in phase!

- With potentiometer P1 a time period between 6 and 60 seconds (selector switch SW in position 1) or between 60 and 600 seconds (selector switch SW in position 2) can be set. With a control current (230 V AC) at terminal 3 the pump delivers corresponding to the preset period of time (P1, SW).
- With potentiometer P2 the rotor speed can be set to operate at a rate of delivery between 0.1 and 2 ml/min. As long as the control current (230 V AC) at terminal 4 is active, the pump operates at the adjusted rate of delivery.
- **IMPORTANT!**
In case of simultaneous control current, channel 1 ("In1") has priority.
- On terminal 11 and 12 a suction line with float switch for supply tank empty detection may be installed. If a supply tank empty is detected, the signal LED L3 blinks. Terminals 5 (neutral conductor) and 6 (phase) lead operation voltage to switch on an external visual or audible warning signal. An optional LED in series with a resistor (560 Ohm) between terminals 9 and 10 may be added.



CAUTION!



IMPORTANT!

Electrical connection

- All installation must be done with the power supply disconnected.
- Installation should proceed in accordance with local rules and regulations.
- Putting the unit into service and carrying out adjustments must be left entirely to appropriately instructed personnel.
- If the machine control doesn't supply a special terminal for the pump, the device must be installed with a multi-polar switch with a contact distance of at least 3 mm.
- Electrical connection should proceed in accordance with the terminal designations in the device.

Putting into service Start-up

After connecting the device to the power supply and activation of the control signal on terminal 3 („In1“), the pump/operates steadily with the rate of delivery preset by the

factory. If necessary, the rate of delivery can be adjusted by potentiometers P1 and P2 in the range, that is specified in the chapter "Technical Data". If a different mode of operation is required, refer to section „setting mode of operation“.

Safety in case of a ruptured pump tube

When using **electrical conductive process fluid**, a damage of the pump tube is detected by electrodes. If the level of the escaping process fluid in the pump housing reaches the electrodes, the pump is switched off and an failure signal is activated. If **a process fluid with very low electrical conductivity** is metered and the rupture of a tube occurs inside the pump housing, the escaping process fluid can be drained with the help of an additional tube that is connected to a tube fitting in the center of the tube retainer.

Maintenance / Wearing parts / Spare parts

The pump tube is a wearing part and has to be exchanged on a regular basis. The maintenance of the chemical feed system is limited to the exchange of this tube, which can be done during normal service.



NOTICE!

NOTICE!

Before installing the EASYDOS Peristaltic V the chemical compatibility of the tube and the process fluid has to be evaluated.

The life span of the pump tube depends on its chemical compatibility and the actual periods of operation.

Spare tube: 138-0.8x1.6 *PharMed®, system back pressure max. 2 bar; 7-400 ml/h
Part number: 37041

Chemical compatibility of the PharMed®-pump tube with the following process fluids:

Aluminum chloride 53%	very good
Aluminum sulfate 50%	very good
Ferrous chloride 43%	very good
Ferrous sulfate 5%	very good
Sodium hydroxide 40%	very good
Sodium hypochloride 12%	very good
Hypochloric acid 10%	very good
Hypochloric acid 37%	good
Sulfuric acid 30%	very good
Sulfuric acid 96%	unsuitable
Hydrogen peroxide 30%	very good
Hydrogen peroxide 90 %	good

For other media please ask the pump manufacturer for the chemical resistance.

Spare parts are available that can be ordered in case of mechanical failure. When ordering spare parts please specify the type of the unit and the serial number.

Spare parts

Tube retainer 0.8x4x1 part no. 37040

Rotor with rolls part no. 37042

*PharMed® is a registered trade mark of Saint-Gobain Performance Plastics.

Changing of the tube without disassembly of rotor

WARNING!

Read the material safety data sheet (MSDS) of the process fluid and obey the described safety measures!

IMPORTANT!

Use original Lutz-Jesco pump tube only! The use of different tubes may damage the drive. **Never grease the tube!**

CAUTION!

Before changing the tube always ensure, that the tubes don't contain residue of the process fluid: Acids and lyes may cause dangerous injuries to your eyes and to your skin. Wear safety equipment (i.e. goggles, gloves, apron, etc.). If necessary, protect the environment from escaping chemical/process fluid.

WARNING!

The turning rotor can cause harmful contusions!

Ensure, that the pump is always disconnected from the power supply, while exchanging the tube (**switch off power supply of the chemical feed system!**)

The pump housing is a wearing part and must be changed after reasonable periods of time according to the following description:

Take off front cover (12) as shown in A.III. Remove cover of pump housing and rotor cap. Pull out tube retainer with old pump tube while turning the rotor by hand. If the pump housing is wet or dirty, due to escaping process fluid, the rotor must be dismantled and the inside of the pump housing must be cleaned and dried carefully. Remove old pump tube from tube retainer and install a new tube without twisting it. Use the tube fixings. Insert tube retainer with new tube into pump housing. Insert tube into the track inside pump housing by turning the rotor by hand. Fasten cover of pump housing.

Disassembling of front cover (12)

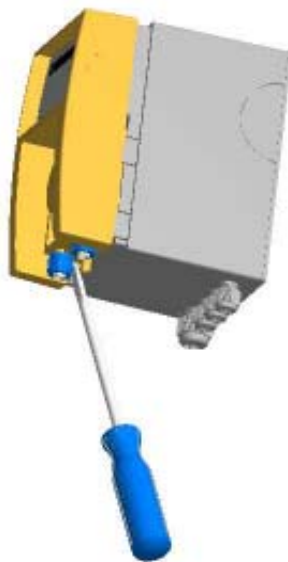

WARNING!



IMPORTANT!



CAUTION!



WARNING!

Declaration of conformity

This declaration is no assurance of characteristics in the sense of the product liability law. The safety notes in the operation & maintenance instructions must be obeyed.

EC – Declaration of Conformity

We, **Lutz-Jesco GmbH**
Am Bostelberge 19
D – 30900 Wedemark

hereby certify
that the product described in the following complies with the relevant fundamental safety and sanitary requirements and the EC regulations mentioned below due to the concept and design of the version sold by us.
If the product is modified without our consent, this declaration loses its validity.

Product description:	Peristaltic Pump
Model designation:	EASYDOS Peristaltic V
Relevant EC regulations:	EC Low-Voltage Directive (73/23/EEC) EC Electromagnetic Compatibility Directive (93/68/EEC)
Applied harmonized standards, especially:	EN 292-1 and EN 292-2, Safety of Machines EN 50081 Parts 1 and 2, EN 50082 Parts 1 and 2, Electromagnetic Compatibility, Emission of Noise and Noise Immunity
Applied national standards and technical specifications, especially:	VDE 0700, Teil 1

Date, Signature of Manufacturer: 2005/05/01 

Information on the signer: **Mr. Lucjan Gogolin, Head of Technical Office**

This declaration is no assurance of characteristics in the sense of the product liability law. The safety notes in the operating instructions must be observed.

Declaration of harmlessness

Contact your local distributor for return authorization.

Declaration of harmlessness

(Please fill in separately for each unit – pump or accessory –)

We forward the following metering equipment to you for repair:

Type (metering pump or accessory): _____

Part No.: _____

Order No.: _____

Date of delivery: _____

Reason for repair: _____

Chemical metered: _____ Properties: Irritating: Yes/No
Corrosive: Yes/No

We hereby certify, that the product has been cleaned thoroughly inside and outside before returning, that it is free from hazardous material (i.e. **chemical, biological, toxic, flammable**, and **radioactive** material) and that the lubricant has been drained.*)

If Lutz-Jesco has to (further) clean the unit the costs will be charged to us.

We assure that the aforementioned information is correct and complete and that the unit is dispatched according to the legal requirements.

Company / Address:

Phone:

Fax:

E-mail:

Customer No.:

Contact:

Date

Signature / Stamp

*) Please delete as applicable!

Please, return declaration with product
by attaching to the package.

Lutz-Jesco GmbH, Am Bostelberge 19
D-30900 Wedemark, Germany

Warranty

Please copy this page and send it back with the EASYDOS Peristaltic V!

If the dosing pump fails during the warranty period, please return the cleaned EASYDOS Peristaltic V with the completed warranty claim.

Sender

Company: Phone: Date:

Address: City ZIP Country

Contact person:

Lutz-Jesco order number: Delivery Date:

EASYDOS Peristaltic V: Serial number:

Max. capacity / max. pressure:

Description of fault:

.....

.....

Type of fault:

1. Mechanical fault

Premature wear

Wear parts

Breakage / other damage

Corrosion

Damage in transit

2. Electrical fault

Connections, plug connectors or cables loose

Operating elements (e.g. switches / push-buttons)

Electronic unit

3. Leaks

Connections

Dosing head

4. Inadequate or no delivery

Diaphragm defective

Others

Service conditions of the dosing pump

Point of use / system designation:

Accessories used (Suction line, PDS, etc.):

.....

.....

Commissioning (date):

Duty period (approx. operating hours):

Please describe the specific installation and enclose a simple drawing of the chemical feed system, showing materials of construction, diameters, lengths and heights of suction and discharge lines.



Lutz-Jesco GmbH

Am Bostelberge 19
30900 Wedemark
Deutschland

Tel.: +49 5130 5802-0
Fax: +49 5130 5802-68
e-Mail: info@jesco.de
Internet: www.jesco.de

24h-Hotline:
+49 5130 580 280

Austria

Lutz-Jesco GmbH

Aredstraße 22 / EG / AR 2
2544 Leobersdorf
Austria

Phone: +43 2256 62180
Fax: +43 2256 6218062

E-Mail: info@lutz-jesco.at
Internet: www.lutz-jesco.at

East Asia

Lutz-Jesco

East Asia Sdn Bhd

Level 26, Menara IMC
No. 8, Jalan Sultan Ismail
50250 Kuala Lumpur
Malaysia

Phone: +603 20394360
Fax: +603 20318359

E-Mail: stephen.lim@jesco.de

Netherlands

Lutz-Jesco Nederland B.V.

Nijverheidstraat 14 C
2984 AH Ridderkerk
Netherlands

Phone: +31 180 499460
Fax: +31 180 497516

E-Mail: info@lutz-jesco.nl
Internet: www.lutz-jesco.nl

Middle East

Lutz-Jesco GmbH

Building no 308, office no 77
Al Dana Commercial Center
Opp. Kuwaiti Building
Skeikh Isa Avenue
Manama, Bahrain

Phone: +973 17 274007
Fax: +973 17 254423

E-Mail: kudchikar@jesco.de

USA

Lutz-JESCO America Corp.

55 Bermar Park
Rochester, N.Y. 14624
USA

Phone: +1 585 426-0990
Fax: +1 585 426-4025

E-Mail: mail@jescoamerica.com
Internet: www.jescoamerica.com



© Lutz-Jesco GmbH 05/05
Printed in Germany